

THE OLSON 30S (911S)

The Olson 30S is 30 feet of pure beauty and power. On the outside it's all business. But below, it's undeniably a luxury cruiser of carefully crafted teak and designer fabrics.

It's spacious interior features a large double berth aft. The main salon includes a port settee with a drop-leaf table that can be folded out of the way. The starboard settee offers additional leg-room as it runs under the nav station's chart table. An attractive liquor and storage rack is positioned on the main bulkhead. A hanging locker is on the port side across from the head.

The L-shaped galley features a fresh water sink with doorway below, utensil drawer, a gimballed 2-burner alcohol stove with oven, a large dry goods locker, an insulated ice box and a trash pass-through.

Forward to starboard is an enclosed head with a hot and cold shower and sink, a toiletries chest and cleaning gear locker. Also forward is a large double v-berth in a private stateroom.

Performance is engineered into every detail of the Olson 30S. Its elliptical keel and rudder provide stability while its tall double-spreader masthead rig provides the power. All halyard and sheeting systems lead to the cockpit for easy handling.

Step aboard the Olson 30S, nothing else comes close.

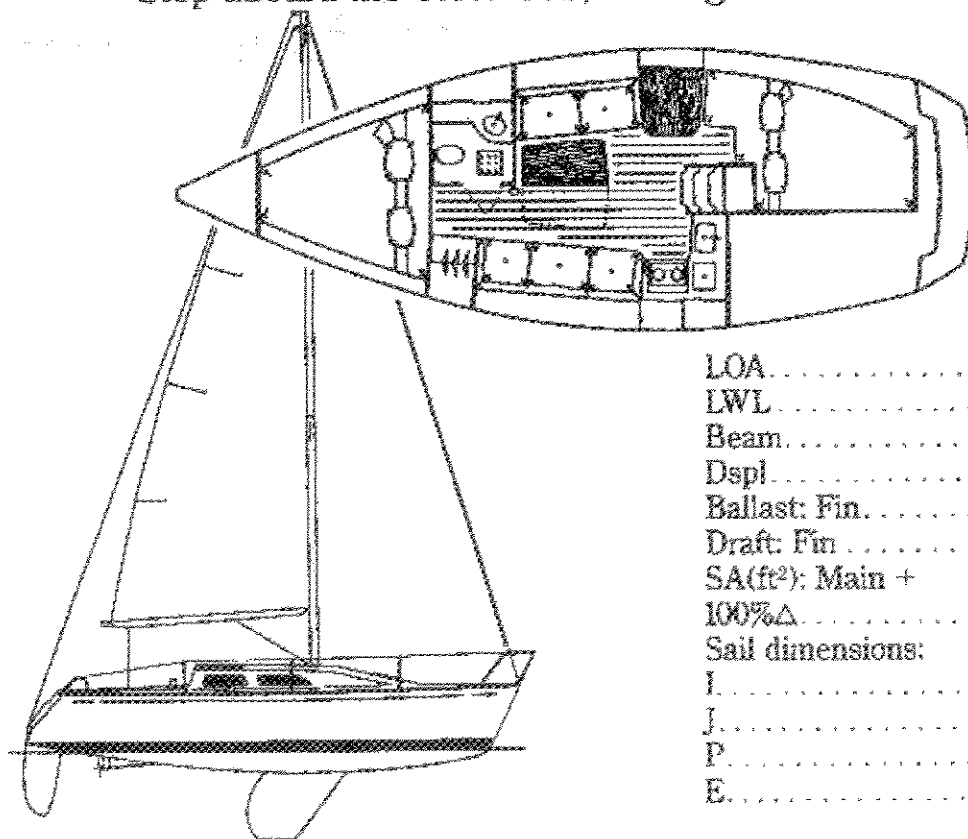

LOA	29' 11"
LWL	25' 0"
Beam	10' 4"
Dspl	7,600 lbs.
Ballast: Fin.	3,200 lbs.
Draft: Fin	5' 5"
SA(ft ²): Main +	
100%Δ	463 sq. ft.
Sail dimensions:	
I	41' 6"
J	12' 2"
P	35' 6"
E	11' 10"

OLSON 91 IS STANDARD EQUIPMENT
3/86

CONSTRUCTION HULL

Hand laminated one-piece monocoque fiberglass hull structure of male, 18 oz bi-directional glass, roving with extra laminate located at high stress areas. Fiberglass beams of Unidirectional roving and woven roving to reinforce the hull and distribute loads from keel mast and engine. Fiberglass bonding of wood bulkheads, berth tops, quarters and mast sheives for additional support of the hull skin. White hull with dark blue boot and cowe stripe. Epoxy coating on keel.

DECK

Hand-laminated fiberglass deck with extra laminate at high stress areas. Resin-cored sandwich construction. Additional reinforcement to core at all high stress areas; stanchion bases, winch bases, traveler, and cockpit sole. Molded in non-skid. Deck color is light gray. The hull to deck joint is a bolted interior hull flange bedded in 3M 5200 compound.

BALLAST

3,200 lbs cast lead elliptical keel mounted externally by stainless steel bolts.

MAST, BOOM & RIGGING

MAST
Double spreader masthead rig (aluminum) with in line uppers, intermediate and lower shrouds. Mast is tapered at the top for minimum weight and wind resistance. "Articulating" boom vang attachment. Clear anodized finish. Stambell shroud attachments. Keel stepped with deck tie down. Tri-halyard masthead assembly with special stainless steel fairing for standard internal jib and optional universal halyards. Internal slots with tag lines for future installation of universal halyards. Internal main halyard Goodenock fitting with reefing hooks. Masthead anchor light. Mid-mast combination bow/foredeck light. Painted headboard band. VHF coaxial cable with connectors.

BOOM

Aluminum boom, clear anodized with mainsheet bale; vang bale; internal sheaves to accept two (2) sets of internal slab reefing; internal outhaul, 4-to-1 purchase. Sail track. Clew band. SOLID BOOM VANG.

STANDING RIGGING

1 x 19 stainless steel shrouds and stays with swaged terminals. Stainless steel turnbuckles. Stainless steel chainplates and tie rod, inboard mounted for close wanded sheeting angle.

RUNNING RIGGING

7 x 19 x 3/16" wire (stainless steel) main halyard spliced to decon tail (internal), led aft to cockpit. 7 x 19 x 3/16" wire (stainless steel) jib halyard spliced to decon tail (internal), led aft to cockpit. Decon braid mainsheet. Jaconobroid jib sheets. Two sets internal reef lines, led aft to cockpit. Color coded halyard tails and reeflines. Seven mainsheet blocks.

WINCHES

sewer 40A, two speed, aluminum genoa sheet (2).
sewer 30A, two speed, aluminum jib halyard. Lewmar 40A, two speed, aluminum main halyard. Lewmar 10" throw lock-in handle (1)

TABLES

North Sails: Main, 7oz with two reefs, insignia. 110% Jib, 6oz. Blue Mainail Cover with insignia.

HATCHES, PORTLIGHTS & VENTILATION

One Lewmar "superhatch" deck hatch. Fiberglass sliding main companionway hatch with solid teak cribboards. Seafood for main companionway hatch. Lewmar opening portlights (2) One in main salon and one in the head. Fixed portlights (4) in main salon.

DECK HARDWARE

Genoa tracks, inboard 1 1/4" x 3/16" aluminum "T" track. Toerail track. Narken ball bearing cockpit mounted mainsheet traveler with controls. Genoa cars (2). Flooring cleats, (3) through bolted with backing plates. Bow pulpit, double rail with backing plates. Stern quarter pulpit, with double gates. Lifelines and stanchions, double, with backing plates. Boring gates in lifelines. Mast collar. Teak cabin top handrails. Solid teak, companionway cribboards. Cockpit seat locker. Cockpit coaming and seats, bio-mechanically engineered for comfort. Cockpit scuppers, self-bailing (2), drain to thru-hulls.

RUDDER AND STEERING

Elliptical rudder, steel reinforced, foam cored with fiberglass skins. 2 7/8" stainless steel rudder post. Fiberglass rudder tube with bearing. Tiller. Wheel Steerer (optional.)

FUEL

15 gallon custom aluminum fuel tank, baffled, deck-filled, shut-off valve, vent and grounded. Fuel tank fill level gauge.

WATER

30 gallons of fresh water; in custom, removable water tank under starboard settee. 30 gallon optional water tank in cockpit locker for optimum weight distribution. Tanks vent at galley sink to allow overflow when filling to spill conveniently into sink and to avoid contamination.

HOLDING

15 gallon, high strength plastic.

POWER

Diesel, Universal 14 hp, 2 cylinder, fresh water cooled inboard auxiliary with Racor fuel filter/water separator. Fiberglass, gelcoat finished engine mount with adjustable motor mounts and contained oil drip pan. 12-volt 55 amp alternator. Instrument panel, recessed at steering station in cockpit console; ignition, tachometer, oil pressure light, temperature gauge, ammeter, engine compartment ventilation blower control switch. Throttle and gear shift. Propeller shaft, 1" model with bronze shaft 2-blade sailer prop. Engine compartment ventilation system with exhaust blower fan. Insulated engine compartment box.

ELECTRICAL

DC
12-volt 85 amp heavy duty marine batteries (2). Distribution panel at navigation station with circuit breakers, spares, service lights, battery condition indicator, ammeter. Four-way master battery switch, sealed. 12-volt cabin lights, dome and spot. Indirect fluorescent lighting, P&S, in main salon. Chart light. Pre-wired for stereo tape deck and speakers (2). Internal dual running lights, bow and stern, mounted on pulpits in custom protective brackets for optimum visibility and safety. Bow and foredeck light mounted on mast. Masthead light.

AC

Distribution panel with service light, reverse polarity light and circuit breakers. Dockside power cord -50 feet. AC outlet below all protected against ground faults.

PUMPING

Hot and cold pressure water to galley, head and shower. Manual bilge pump, whale, cockpit mounted. Electric bilge pump. Thru-hull fittings, flush-mounted below waterline with ball valves of Zytel. Double hose clamps on all hoses below waterline.

INTERIOR

6' headroom with leatherette headliner and deck access zippers. Teak bulkheads. Teak cabin house trim. Fabric hull finish. Cabin sole, teak and holly with access covers. Oiled, hand rubbed teak finish.

GALLEY

"L" shaped, 10" deep stainless steel sink with drain thru-hull and doorway below. Brewer, 2-burner gimballic alcohol stove with access. Large dry goods locker with smoked plexiglass sliding doors. Trash basket.

ICE BOX

Top loading insulated ice box outboard of sink at galley.

BERTHS (6)

Double quarterberth. Port settee in main salon. Starboard settee in main salon with footthrough at chart table. Double forward berth in stateroom.

NAVIGATOR'S STATION

Chart table with opening lid-storage below. High intensity chart light. AC/DC electrical distribution panel.

HEAD AND SHOWER

Large head compartment with mirror. Ceramic head, 13 gallon holding tank with dockside discharge (overboard optional). Basin, fiberglass, drains to thru-hull. Mirror. Cleaning gear locker. Toilettries compartments. Hot and cold water to sink and shower. Sealed 110 Volt AC outlet, ground fault protected. Opening port for ventilation. Formica bulkheads for easy cleaning. Shower curtain. Light overhead.

MAIN SALON

Drop leaf dinette table for dining and socializing. Table folds to main bulkhead when not in use. Liquor and storage rack on main bulkhead. Large lockers port and starboard. Hanging locker.

INTERIOR FINISH

Hand rubbed, sanded oiled teak. Solid teak framed cutout for doors and drawers. Decorator fabric for cushion covers. Foam cushions, 4" pillow style in the main salon with pillow style backrests. Decorator fabric on hull sides. High-density 4" foam cushions in the forward and aft berth for comfortable sleeping. Fabric doors with zippers on locker openings, black.

ADDITIONAL FEATURES

Flush mounted thru-hulls below the waterline. Access for knotmeter and depth finder transducers. Heat wire terminal connection strip on underside of deck for ease of wire connection.

WARRANTY

10-year limited hull warranty. Ask your dealer or Olson Sailboats/Ericson Yachts for a complete copy of our limited warranty.

5 YEAR BLISTER PROTECTION POLICY

Ask your dealer for details.

Due to our continuing commitment to improve our products, we reserve the right to change specifications without notice.

Prices are subject to change without notice.

OLSON 911S ORDER FORM -RETAIL PRICE LIST

Hull Identification # ERY91

Dealer _____ Ship To _____
 Customer _____ Address _____

HULL COLOR #069 WHITE STD DECK COLOR #013 DOVE GREY NON SKID COLOR #013 DOVE GREY
 BOOT STRIPE COLOR # 542 MIDWATCH BLUE BOTTOM PAINT COLOR: NONE
 MAST COLOR: CLEAR ANODIZED
 KEEL TYPE: DEEP
 SHEER 1" COVE COLOR #542 MID. BLUE TAPE INTERIOR CUSHIONS TO BE _____

50228 _____ Universal 14hp Diesel Engine-Model 18/2Cyl (fresh water cooled)..... STD
 50237 _____ Standard Propeller: 2 Blade 12 x 12 x 1" RH..... STD

- OL91000 _____ Cockpit cushions (2). Color: _____ \$211.00
- OL91001 _____ Compass, Ritchie SP-5, 5" (pedestal mount, requires wheel option)..... \$395.00
- OL91002 _____ Curtains with piping on all ports. Color: _____ \$250.00 ✓
- OL91003 _____ Cushions, fabric A, in lieu of standard..... \$294.00 ✓
- OL91004 _____ Head-overboard discharges..... \$295.00 ✓
- OL91005 _____ Martec folding propeller in lieu of std: 13 x 12 x 1" RH-1K3..... \$488.00 ✓
- OL91006 _____ Roller furling system for headsail w/deck hardware (Harken Unit #1)..... \$1,445.00
- OL91007 _____ Sails, main with 2 reefs, and logo..... STD
- OL91008 _____ Sail, 110% lapper..... STD
- OL91009 _____ Sail, 110% lapper for roller furling w/UV cover on leech & foot in lieu of std..... \$347.00
- OL91010 _____ Sail, 135% genoa _____ \$ PTF
- OL91011 _____ Sail cover, blue with white Olson logo..... STD
- OL91012 _____ Stove, CNG 2-burner w/oven in lieu of standard (S/S finish)..... \$1,145.00
- OL91013 _____ Shipping cradle - steel, w/adjustable pads..... \$1735.00
- OL91014 _____ Ship on pads (not cradle)..... \$267.00
- OL91015 _____ Water tank, additional, 30 gallons..... \$365.00
- OL91016 _____ Wheel steerer, 28" destroyer wheel w/brake, ped. guard & emergency tiller..... \$1,995.00
- OL91017 _____ Winches, main & jib halyard, Lewmar 30AST (self-tailing in lieu of std)..... \$422.00
- OL91018 _____ Winches, sheet (2), Lewmar 40AST (self-tailing in lieu of std)..... \$427.00
- OL91019 _____ Winches, sheet (2), Lewmar 43AST (self-tailing in lieu of std)..... \$714.00
- OL91020 _____ Winches, secondary sheet (2), Lewmar 40A..... \$707.00 ✓
- OL91021 _____ Winches, secondary sheet (2), Lewmar 40AST..... \$1,065.00

DEALER: _____
 ORDER ACCEPTED BY: _____

TOTAL OPTIONS \$ _____
 BASE PRICE \$ 47995.00
 SUB TOTAL \$ _____
 SPECIALS \$ _____
 TOTAL PRICE \$ _____
 LESS DEPOSIT \$ _____
 NET PRICE \$ _____

NOTE: NO CHANGES, ADDITIONS, OR DELETIONS ARE AVAILABLE FROM THE STANDARD OR OPTIONAL EQUIPMENT ON THE OLSON MODELS.

ALL PRICES AND SPECIFICATIONS ARE SUBJECT TO CHANGE WITHOUT NOTICE.
 PRICES ARE F.O.B., IRVINE, CA. REQUIRES OPTIONS OL91014 OR OL91013

Effective 3/88

OLSON



Manufactured by Ericson Yachts, Inc.
 1931 Deere Avenue
 Irvine, CA 92714
 714/250-7000